



# BROWNELLS®

SELECTION. SERVICE. SATISFACTION.

200 S. Front St. Montezuma, IA 50171  
800-741-0015 or 641-623-4000 • www.brownells.com  
World's Largest Supplier of Firearms Accessories and Gunsmithing Tools.™

## .22 CALIBER BARREL LINING INSTRUCTIONS & EQUIPMENT

by RALPH WALKER  
with additional technical information from  
WILLIS SPRUNGER and BOB SCHUETZ\*\*\*  
and the crew at Brownells, Inc.

### .22 BARREL RELINING - WHY?

Because it frequently is the only way to save a useful, functional and otherwise fine, old or shot-out gun from the scrap heap. Also, most of the classic .22 Rimfire rifles produced prior to WWII, and some models produced up to the 1960's, have become valuable collector items. Replacement barrels with the original contours and factory markings are virtually non-existent. This is particularly true of rifles with octagon or half-octagon barrels. Add to that all the other .22 Rimfires with defective bores, muzzle damage, chamber damage or excessive headspace, and there become hundreds and thousands of .22's bedding barrel relining.

In addition, being able to provide this valuable service to your customers will introduce you to a whole new area of gun work. Factually, it is a profitable operation - one that will bring more dollars into your shop, improve your standing in the gunsmithing fraternity and keep customers from having to be turned away - or worse yet, referred to another shop for work you can provide with a minimum of investment in time and money.

### TECHNICAL SPECIFICATIONS OF THE BROWNELLS .22 CALIBER BARREL LINER

**Caliber:** .22 LR or .22 Magnum, Rimfire only.

**Groove Diameter:** .223

**Outside Diameter:** 5/16" (.3125")

**Twist:** One turn in 16".

**Length; overall:** Made to approximately 26%. Designed for 25" useable length.

**Steel:** Chrome-Moly seamless drawn tubing.

**Rifling:** Shallow groove, narrow land for less bullet deformation and better accuracy.

### TOOLS

The tools and equipment necessary to reline a .22 barrel are both few and simple and so is the process. The only requirement is patience and pride in craftsmanship on the part of the person doing the relining and a willingness to read and follow these instructions carefully.

1. The power source is a 3/8" electric hand drill, variable speed preferred (see Special Notes, page 9).
2. Brownells special 8mm, .315" diameter Barrel Liner Drill with pilot.
3. A sturdy bench vise with padded jaws.
4. A good supply of Brownells Do-Drill™ cutting oil.
5. A squirt-type can to apply the Do-Drill.
6. TCE Cleaner/Degreaser to degrease barrel before bonding liner.
7. A chip brush to clear metal chips from the drill.
8. A standard .22 cleaning rod with bronze bore brush attached.
9. Headspace gauge for your specific .22 Rimfire cartridge.
10. Finish Chambering Reamer for your specific .22 Rimfire Cartridge.
11. Large tap handle to drive the reamer.
12. Dummy ammo for the specific .22 Rimfire cartridge you're doing.

\*\*\* The late Ralph Walker, Walker Arms Co., Selma, Alabama; the late Willis Sprunger Gun Shop, Winterset, Iowa; Bob Schuetz, SGW, Inc. Olympia, Washington.

©2007 BROWNELLS, INC.

077-200-143 Aug, 07r

All rights reserved. Any reproduction or other usage of form or content of these instructions, either in whole or in part, is expressly prohibited without the prior consent of copyright holder.

### PREPARATION FOR DRILLING

1) The first step is to totally disassemble the rifle, removing all internal parts and any external parts attached to the barrel. Be sure to remove the ejector if it is attached to the side of the receiver. Thoroughly clean the barrel, especially the accumulated dirt, leading and powder residue around the chamber and in the extractor cuts in the barrel. (Clean the breech bolt thoroughly and see that the extractor is functioning freely.)

2) Next, determine if the barrel must be removed from the receiver. If you have straight, clear access to the barrel chamber through the receiver, the barrel can be both drilled and lined with the receiver attached. If not, remove the barrel from the receiver, taking care not to scar it in the process. (We recommend removing the barrel on "first" jobs and on those with complex extractor and feed ramp cuts.) Most .22 barrels use a cross pin to secure the barrel to the receiver, while others screw into the receiver. Close examination and, if available, studying an exploded drawing may help determine which method is used.



**FIGURE 1** - Note severely eroded chamber. Barrel lining will eliminate this and restore accuracy. During examination, make as detailed a drawing as possible, showing location and details of extractor cuts, feed ramps, bullets, etc.

3) Examine the chamber end of the barrel closely (See Figure 1). Note where the extractor cuts are and the location and shape of any bullet guide or feed ramp. A drawing of the original chamber end of the barrel should be made as a guide for positioning the liner and making extractor and feed ramp cuts. A drawing of the type of muzzle crown used on the original barrel (concave, convex, counterbored, flat, stepped, etc.) will also be useful, and should be made. A very quick and easy substitute for making a drawing is to use Cerrosafe™. Simply make a casting of the original chamber end of the barrel as well as the muzzle. You will now have perfect patterns to duplicate.

4) The barrel will be drilled half its length from the muzzle end, and halfway from the chamber end (See Figure 2A). To make certain the hole is drilled to the proper depth from each

end and to provide a smooth joining and overlap of the two holes, measure the length of the barrel, divide by two, and then add one inch to this measurement. Transfer this measurement to the drill bit, measuring from the drill's cutting edge, NOT the pilot end. A piece of tape wrapped around the drill at this point serves as a drill stop gauge. By drilling halfway from each end, you assure maximum, accurate alignment of both liner ends and eliminate the necessity of an even longer drill shank and the problems inherent with the type of drill.



**FIGURE 2A & 2B** - Barrel is drilled *SLOWLY* with lots of oil, frequent chip removal and cleaning. Drill half of barrel length from each end with 1" overlap.

5) Chuck the shank of the Brownell Barrel Liner Drill into your variable-speed, electric hand drill and use the chuck key to tighten securely. Do not just hand-tighten, as the chuck will slip during drilling.

6) Finally, secure the barrel in the padded jaw bench vise. Make it as close to level as possible, parallel to the bench top. This makes holding the drill level and cutting a smooth hole much easier. On tapered barrels, you may need to lay a cleaning rod in the bore as a leveling guide.

### DRILLING THE BARREL

1) Apply a liberal supply of Do-Drill cutting oil up into the bore of the barrel and also over all the areas of the drill that are going into the bore. As you cut deeper into the bore, you must keep oiling more and more of the drill's shaft. An adequate supply of cutting oil during the drilling operation is very important, and there is no such thing as too much cutting oil! (See Figure 2B.) Use a cloth or splash pan on the floor to catch oil and chips.

2) By standing directly behind the drill and viewing down, you can align, and keep, the drill straight, right to left. Have a friend give instructions for up and down alignment by viewing the barrel and drill from the side, eye level with the bore. The extra person should not be necessary after a few barrels are done as you will learn, from the "feel" of the drill cutting properly, how much alignment is necessary.

3) The drill should *cut slowly and steadily* as it progresses through the barrel. Heavy pressure exerted on the hand drill

is NOT necessary and will prevent acquiring the feel of the drill cutting properly. It also causes the drill to bite and possibly jam. The pilot on the drill will guide it through the barrel without any problem unless you push the hand drill to one side or bow the drill with excessive pressure.

If, after drilling several barrels, the liner drill is not cutting cleanly and smoothly, it is probably due to a dull cutting edge. This is generally the result of an overheated drill bit and burned cutting edges caused by too much pressure or drilling too deeply before removing the drill and allowing it to cool. The cutting edge can be touched-up by lightly stoning it with an Arkansas stone. DO NOT grind the drill or alter the angle of the original cutting edge. A little stoning goes a long way, so test the drill several times during the stoning.

If the drill bites too much and jams, especially with a new drill, the cutting edge of the drill may be too sharp. Using an Arkansas stone, very lightly break the edge of the cutting angle. Go easy on the stoning and test the drill several times during the stoning. (It must cut evenly without grabbing, if you're ever to drill a 26" -28" deep hole!) Also see *Special Notes*, page 9.

As a general rule, the liner drill, like all drills, cuts better after some use. For this reason, and to learn the feel of when the drill is cutting properly, we recommend that you drill two or three junk barrels before the first lining job. This usually cures the tendency of the drill bit to stick or jam.

Experience is the best teacher and correct barrel drilling procedure depends 50% on the operator's experience. Remember, the drill should cut slowly and steadily with only minimum pressure. Probably 90% of all drilling problems are due to too much pressure, trying to get the job done too quickly, or an underpressure drill.

4) The correct drilling technique is to drill about 1" deep, then withdraw the drill from the barrel, brush away all chips from the drill flutes and clean the bore of all metal chips with the bore brush or compressed air. Let the drill spin freely for a few seconds before pulling it out to help prevent the buildup chips from jamming the drill. (Continuous drilling of more than 1½" to 2" without removing the drill can overheat the drill, burn the cutting edges and cause an excessive buildup of metal chips that will lead to a drill wedged up inside the bore.) Flood the hole with Do-Drill and apply some to the drill. Then drill another 1". Keep repeating this sequence until you reach the section of tape on the drill.

5) Now drill from the opposite end of the barrel in the same drill/clean; drill/clean sequence, until the holes overlap.



**FIGURE 3** - Chamber end of drilled barrel. Note: Cutting oil must be thoroughly cleaned off before **ACRAGLAS**® sing.

6) Once the drilling is completed, remove the barrel from the vise and clean the drilled hole with TCE Cleaner/Degreaser to remove any trace of cutting oil. Also, clean the receiver if it is attached to the barrel (See Figure 3).

**A special note on cleaning solvents:** Do not use petroleum base solvents like gas, kerosene, mineral spirits or gun cleaners. Also, some of the newer ones like MEK won't work either, as they leave a film, or coating, on the metal. If you do not have TCE Cleaner/Degreaser available and want to use another solvent, test it first by swabbing a little of it on a clean window pane. If it leaves a completely clear window when evaporated (no fine, nearly invisible film) **and** will remove grease and oils, it will probably work satisfactorily for you.

### PREPARATION OF THE LINER

1) Round the end of the liner slightly to remove any burrs and try the liner in the drilled hole. It should fit a bit tightly, but only hand pressure should be required to push it from one end of the barrel to the other. If the liner fit is too tight, run the liner drill, under power, through the barrel from both ends. If this is not sufficient, the outside surface of the barrel can also be polished until the fit is correct. Do not over-polish or the fit will be too loose. Never beat the liner into the barrel with a hammer or mallet, this deforms the liner and may jam it into the barrel. (See Figure 4A.)

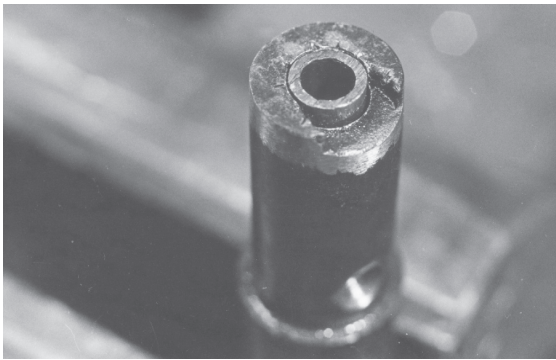

**FIGURE 4A** - Chamber end of barrel with squared-off liner in place, checking for tight fit.

2) The next step is to square off one end of the liner perpendicular to its bore. First, cut off ½" to 1" from one end of the liner. This gets you past any possible damage done to the liner during manufacture, shipment or preparation for installation. Carefully file the newly cut end of the liner square, using a machinist square or other aid against the side of the liner tube for reference. (See Figure 4B.)

**Important Note:** The breech end of the liner has a groove approximately .090" wide around the exterior of the liner. Make sure this end is at the breech, not at the muzzle.

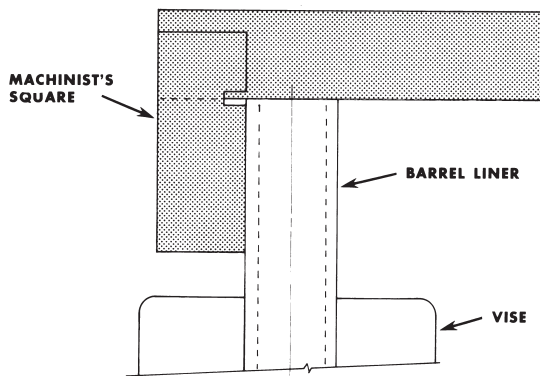

**FIGURE 4B** - The end of the liner that will be at the breech end of the barrel must be squared off using a file and a machinist's square to ensure accuracy.

### CUTTING THE CHAMBER

There are two basic types of chambers used on .22 rifles.

**Type 1 Chamber** consists of the cartridge rim being recessed into the barrel. **Type 2 Chamber** (the most common) contains just the cartridge body in the chamber; the rim is seated into the recess that is machined into the face of the breech bolt.

Chambering for both types of chambers is generally much easier to do before the liner is bonded into the barrel. Cutting extractor slots, etc., is easier, too. However, there are exceptions and you must carefully look over each job before you make your decision. For instance, on those guns with a feed ramp or cartridge guide as an integral part of the barrel, the liner should be bonded first. See sections on *Extractor Cuts* and *Feed Ramps and Cartridge Guides*.

### Type 1 Chamber (Cartridge Head in Barrel)

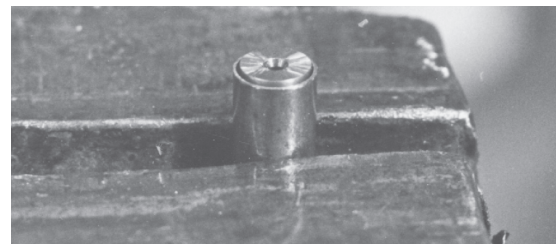

**FIGURE 5** - Liner ONLY in padded vise jaws, chambering reamer in place.

1) Clamp the liner ONLY in a padded vise, straight up and down, with the squared-off end protruding about 2" above the vise jaws. Do not overtighten the vise or you will crush the liner (See Figure 5).

2) Cut the chamber into the liner, including the recess for the cartridge rim. Do the job by hand, using a "T"-handled tap wrench to hold and turn the finish reamer. (A rougher is generally not needed.) Cut slowly, use lots of Do-Drill; clean reamer and chamber often.

3) Insert the Go headspace gauge into the newly cut chamber. Now, lay a straight edge, such as a 6" metal ruler, across the liner and headspace gauge. Any gap between the rear face of the headspace gauge and the straight edge means excess headspace. To correct, face off some of the rim of the liner. If the



**FIGURE 6** - Headspace gauge in place - chamber too shallow.

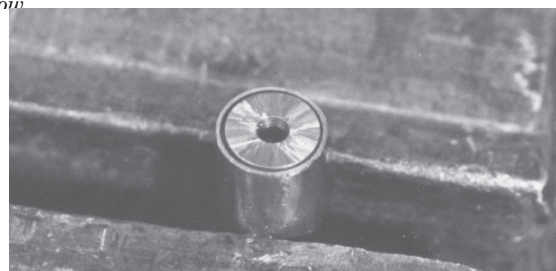

**FIGURE 7** - Headspace gauge in place - chamber depth correct. Note thin rim of liner left around Headspace gauge in **Type 1 Chamber**.

straight edge touches the headspace gauge and not the liner, the chamber is too shallow and must be cut deeper. **Headspace is correct when the straight edge touches both sides of the liner and also touches the rear face of the headspace gauge** (See Figures 6 & 7).

4) When the chamber has the correct amount of headspace, take the liner out of the vise and push it through the barrel from the muzzle end until rim edges are flush with the rear face of the barrel. Use only hand pressure; do not tap or force the liner as you will damage the newly cut chamber rim if you do. This flush-rear position must be maintained when locating the extractor cuts and during bonding in order to maintain correct headspacing. You may wish to make fine index marks on the barrel and liner to ensure correct repositioning of the liner after each removal.

### Type 2 Chamber (Cartridge Head in Bolt Face)

1) Clamp the liner ONLY in a padded vise, straight up and down, with the squared-off end protruding about 2" above the vise jaws. Do not overtighten the vise or you will crush the liner (See Figure 5).

2) When cutting a **Type 2 Chamber** in a liner, it is only necessary to cut until the rim section of the finish reamer touches the face of the liner. (Rougher is generally not used.) Cut slowly, use lots of Do-Drill, and clean often.

3) With the liner mounted vertically in the vise, insert the Go headspace gauge in the newly cut chamber. Place the breech bolt, with the extractors removed, on the end of the liner. (See Figure 8). By close examination under a strong light you can determine if the rim recess in the bolt is correct. If the face of the bolt does not touch the liner, first examine the rim recess in the bolt face to see if there is any "crud" keeping the bolt from seating correctly. If the bolt recess is clean, then your chamber is not deep enough, and must be cut deeper.

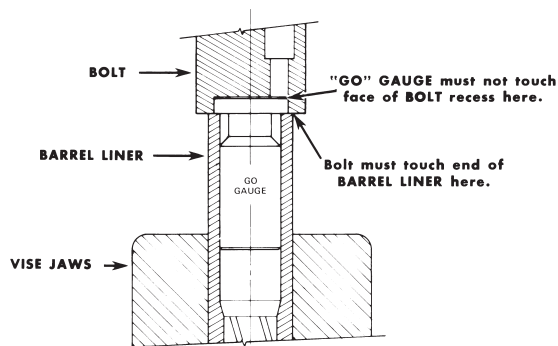

**FIGURE 8** - Bolt positioned on top of the liner with Go gauge in place. End of the liner contacts the bolt, while the rear face of the headspace gauge DOES NOT.

Go slowly, cutting only .001" at a time and check with the headspace gauge and bolt after each cut **until the bolt face touches the barrel liner edge** as described above. Use Do-Drill and clean after each cut. This additional depth will cut a shallow rim recess in the barrel liner itself, and must be done so the bolt's forward movement during loading is stopped by the rear face of the lined barrel, not the cartridge rim. If the rim stops the bolt, additional pressure on the bolt can cause the cartridge to fire before the bolt is fully closed and/or locked.

If the rim recess in the liner is cut too deeply, excessive headspace will result. This can be corrected by lightly filing the rim edge you have just cut into the liner.

### EXTRACTOR CUTS

As mentioned earlier, extractor cuts are best done prior to

bonding. Instructions for making extractor cuts on both **Type 1** and **Type 2 Chambers** are covered in this section. The exception is on single-shot rifles where the extractor takes up a considerable area of the rear of the liner. With this type of extractor, first bond the chambered liner and then cut away the liner a bit at a time until proper clearance for the extractor is achieved (See Figure 9).



**FIGURE 9** - Large extractor cutout requires bonding liner in barrel before making cutout.

### Type 1 Chamber (Cartridge Head in Barrel)

1) In **Type 1 Chambers** with small extractor cuts, push the liner forward until it is flush with the face of the original barrel. Using a sharp scribe, carefully mark the location of the extractor cuts, checking your marks against the drawing you made.

2) Remove the liner and carefully make the necessary extractor cuts in the liner. Needle files work very well for this, but any other method that cuts cleanly and precisely will work. Reinstall the liner in the barrel.

3) Reinstall the barrel on the receiver; reinstall the extractor; and, holding the liner in place with your hand, insert a dummy cartridge in the chamber and work the action to be sure it will extract the cartridge. It's easier to correct problems now rather than after the liner is bonded into the barrel.

### Type 2 Chambers (Cartridge Head in Bolt)

1) Follow steps 1 and 2 above.

2) Reinstall the extractors on the breech bolt and with the liner in place in the barrel, check to be sure they will extract a dummy cartridge from the chamber in the liner.

3) Reinstall the bolt and the barrel on the receiver. Holding the liner firmly in place with your hand, insert a dummy cartridge in the chamber and work the breech bolt through its full cycle to be sure it will extract the cartridge. Make whatever corrections are necessary now, before you bond the liner in the barrel.

### FEED RAMPS AND CARTRIDGE GUIDES

On barrels where a feed ramp or cartridge guide is an integral part of the barrel, the drilling operation will cut away part of the ramp or guide. This must be replaced. The **unchambered** liner is slid out past the breech end of the barrel until the rear edge of the liner mates with the fresh cut on the feed ramp. Bond in place in this position. The portion of the liner which replaces the drilled away section of feed ramp must now be filed to match the contour of the original feed ramp. The rest of the liner is filed to match the existing breech face. Now, chamber headspace and cut extractor slots.

### BONDING THE LINER

There are two common ways to bond the barrel liner to the drilled barrel, Hi-Force 44™ solder or epoxy. Soldering has

been around for a long time and can be difficult and time consuming to do. The epoxy method is relatively new, beginning in the early '60's. The late Ralph Walker, Walker Arms, Selma, Alabama, started **ACRAGLAS**ing barrel liners in place in 1963. Liners installed then are still in everyday use, and not a single one has come loose. In fact, one barrel, relined in 1964, has been immersion hot blued twice without liner separation. Because it is so much easier to do, and has been very successfully done for many years, we will discuss **ACRAGLAS**ing barrel liners first.

### BONDING WITH ACRAGLAS

1) Thoroughly clean the hole drilled in the barrel and the outside surface of the liner with TCE Cleaner/Degreaser to remove all traces of oil. **ACRAGLAS** will not bond on an oily or waxed surface. Lay the liner on a clean surface and mount the barrel in the vise, breech or muzzle end up, tipped slightly from vertical. (See Special Notes Page 9 for more comments.)

#### STOP

Before proceeding, look carefully at the gun you are working on. If you have followed the steps to this point, the liner is fitted and ready for installation in the barrel, and the barrel is back on the receiver. Read over the section following, looking at the rifle in your hand and think through what you will do and how you will do it; where the extra **ACRAGLAS** is going to go and how you're going to clean it up. Then decide if you want to leave the barrel attached to the receiver or not. Some guns cause no problems. Others - those with fully enclosed bolts, very small ejection ports and no way to get at the breech face of the barrel - simply must be disassembled before attempting to put the liner in place.

2) Next, thoroughly coat all surfaces on the receiver and breech bolt with **ACRAGLAS** Release Agent, **ACRA-RELEASE™**, RIG or paste wax. While the release agent is drying, assemble all the things you will need to mix, cool, apply and clean up the **ACRAGLAS**. These specific supplies include:

2.1) .22 caliber cleaning patches or similar, approximately ¾" square. Anything bigger will tend to squeeze the **ACRAGLAS** out of itself as it enters the bore and prevent you from getting a good, even coat of **ACRAGLAS** inside the barrel.

2.2) A .22 caliber rifle cleaning rod with a slotted tip.

2.3) A throw-away acid brush, or other small brush, for applying **ACRAGLAS** to the outside of the liner. (It must be stiff enough to adequately apply the cold **ACRAGLAS** which gets to be about the consistency of cold syrup as it is chilled.)

2.4) An old T-shirt or similar clean material that can be torn into two or three rags and used to wipe up **ACRAGLAS** runs and spills. DO NOT use paper towels, bench wipes or such that will stick in the **ACRAGLAS** rather than clean it up.

2.5) A bottle of regular cooking vinegar. We prefer white; but have no reason for recommending it, other than it seems to be readily available and doesn't smell quite as bad as the good old-fashioned cider type. All work equally well in removing **ACRAGLAS** that is still in the liquid state. We know of no other chemical or solvent that is as readily available or works as well as the acetic acid in vinegar for removing a non-cured or kick over **ACRAGLAS**. It will not work once the **ACRAGLAS** has started the cure cycle and is no longer fluid. **NOTE:** Vinegar may damage some blued finishes. Be Careful!

2.6) A small wood block to protect your hand when pushing the liner into the barrel.

2.7) A small container to hold ice water to cool the **ACRA-**

**GLAS** and extend its pot life, and your working time. We found a small plastic container ideal; anything will work, however. Just remember to keep the ice water level well below the level of the top of the **ACRAGLAS** mixing cup, and all water and ice out of the **ACRAGLAS** itself.

2.8) A pair of tight fitting rubber gloves to keep you from getting **ACRAGLAS** on your hands, and to keep you from possible aggravation of any skin allergy to the petrochemicals from which **ACRAGLAS** is made.

3) Mix the **ACRAGLAS** according to the instructions with the kit, leaving out the floc and walnut stain (See Figure 10).



**FIGURE 10 - ACRAGLAS** kit comes with everything needed. Mix according to Instructions, but leave out the floc and walnut stain.

You may wish to use Epoxy Black coloring; however, the **ACRAGLAS** line is so thin it is not really required. (Generally about 1¼ oz. of mixed **ACRAGLAS** is more than enough. You may wish to mix more for the first two or three liners you do, "just to be sure" until you know what your usage will be.)

Next, place the thoroughly mixed cup of **ACRAGLAS** in the pan of ice water prepared above. Be careful to keep water out of the **ACRAGLAS** as it can contaminate it and prevent it from hardening correctly.

4) Wipe down a .22 caliber rifle cleaning rod and slotted tip with TCE Cleaner/Degreaser and insert a clean .22 caliber cloth patch (or similar) in the slotted tip of the cleaning rod. Dip the patch in the **ACRAGLAS** and run it through the barrel, remove the **ACRAGLAS**ing patch, for if you pull it back through, you will simply wipe off the **ACRAGLAS** you just applied. Recoat the patch and repeat this application step two or three times to ensure a good, heavy coating of **ACRAGLAS** inside the barrel.

5) Thoroughly coat the outside surface of the liner with **ACRAGLAS**. We found a small acid brush ideal for doing this



**FIGURE 11 - Liner coated with ACRAGLAS, ready to install.**

job. (See Figure 11.) It is extremely important that all surfaces to be bonded receive a good coating of **ACRAGLAS**. It is always better to apply too much rather than not enough. **Note: Be sure you have Release Agent on all surfaces you do not want to ACRAGLAS together.**

6) Insert the liner in the barrel. There are two ways this can be done. (See "Special Notes", page 9.)

**FROM THE MUZZLE END:** (Our preferred method). Insert the Go headspace gauge in the chamber, or plug the end of the liner with modeling clay if it is unchambered. Start the chamber end of the liner into the muzzle of the barrel and push the **ACRAGLAS**-coated liner up into the barrel until it nears the breech end, using a block of wood in your hand to keep from injuring it on the liner's muzzle end. Meanwhile, with your free hand, hold an old T-shirt or other rag at the breech end of the barrel and catch the **ACRAGLAS** being pushed out of the drilled barrel ahead of the liner as it comes up from the muzzle. The amount of **ACRAGLAS** pushed ahead of the liner is usually quite small. Most of the excess is scraped off the liner as it enters the barrel. We placed a cardboard box on the floor below the vise and caught this excess as it ran off.

**FROM THE BREECH END:** (Use this method only with the barrel removed from the receiver.) Plug the muzzle end of the liner with modeling clay to keep **ACRAGLAS** from getting into the liner. Be careful handling the chamber end of the liner to avoid damage or distortion of the rim edges, etc. You might want to insert the Go gauge (coated with release agent) to protect the new chamber and give you a pushing surface. Push the liner in with one hand while holding a clean rag around the breech end of the barrel. This will catch most of the **ACRAGLAS** that scrapes off the liner as it is pushed down through the chamber end of the barrel and out the muzzle. You will have a tremendous amount of runoff at this point, and you must be very careful to thoroughly clean all the runover **ACRAGLAS** out of the threads of the barrel, along the barrel itself and so on, before allowing it to set up.

#### STOP

Vinegar and a soft cloth can be used to wipe off thin films of **ACRAGLAS** from barrel faces, headspace gauges, out of extractor slots, etc. This must be done while the **ACRAGLAS** is still liquid. If set up, vinegar will not remove it.

7) Use a soft, cotton cloth, thoroughly soaked with Brownells TCE or Alcohol, to clean up any spills, runs or excess **ACRAGLAS** from the barrel, threads, end of the liner, the cleaning rod and tip, and anywhere else you may have gotten it. (It also works extremely well to clean up your hands.) Leave a small amount of **ACRAGLAS** around the muzzle end of the liner to ensure a clean, filled joint between the liner and the barrel once the **ACRAGLAS** sets. You may need to add this small amount just as the **ACRAGLAS** in the ice water is finally beginning to kick over in order for it to stay in position and not run out. The chilled **ACRAGLAS** will give you from 45 to 60 minutes during which to move and adjust the liner in the barrel. (We found we had plenty of time, and normally took the still liquid **ACRAGLAS** out of the ice water long before it had started to thicken enough to prevent any additional movement.) If you did not ice the **ACRAGLAS**, you will have only about twenty minutes total time from the first mixup to the initial kick over when the **ACRAGLAS** is no longer fluid. We do not recommend that you ever attempt to **ACRAGLAS** bond a barrel liner without slowing the kick over time of the **ACRAGLAS** by cooling it in ice water. You simply run the risk of not having enough time to do the job correctly and it is not worth taking that risk.

8) If you have disassembled the gun in order to put in the new liner, now is the time to reassemble. Clean up the barrel

breech face thoroughly and all other **ACRAGLAS** spills or runs. Reassemble the barrel to receiver.

9) With the gun assembled and the liner in the exact position you want it to remain, close the breech bolt, taking care that the extractors are fully engaged on the headspace gauge. Set the gun or barrel in a rack, muzzle up, and place a weight on the end of the liner. The weight assures the liner is pushed fully to the rear and that proper headspace is maintained. This step also takes up any excess headspace due to a loose breech bolt as the weight pushes the breech bolt back against the locking surface. **Special Note:** On rifles such as semi-automatics, the breech block is held forward only by spring pressure. On these guns, the weight placed on the end of the liner should only be sufficient to push the liner back until it fully engages the breech block when the breech block is in its most forward position.

10) Allow the **ACRAGLAS** to kick over and fully cure all before removing the weight. Allow a minimum of 24 hours and **Don't Rush It!**

11) When the **ACRAGLAS** has cured, remove all Release Agent from the receiver and the breech bolt. Any excess extruded **ACRAGLAS** can be cut away with a sharp knife blade. Install a dummy cartridge and check for proper extraction.

12) If a new extractor is to be fitted, it should be done now. With the new extractor positioned in the extractor cutout, use the chambering reamer to cut correct clearance and fit for the cartridge rim in the extractor. (See Figure 12.)



**FIGURE 12** - Liner bonded, new extractor being fitted using chambering reamer to cut proper case body and rim clearance extractor.

#### BONDING WITH SOLDER

1) Follow the same basic procedures for drilling the barrel, checking the headspace and cutting clearance for extractors, feed ramps, etc. The same factors all apply.

**SOLDER:** We recommend Brownells Hi-Force 44 Solder because of the high silver-to-tin content, its superior holding qualities, ease of application and resistance to damage from hot bluing. Use No. 4 Comet Flux with Hi-Force 44.

**HEAT SOURCE:** Normally one propane torch puts out enough heat to successfully tin the liner. But, to tin the barrel - and to insert the tinned liner into it, you will have to use 2 propane torches. This means a helper will have to play one torch over the barrel while you work with the other and also insert the liner. **DO NOT** use Oxy-Acetylene to tin or solder. The flame is sooty and will quickly contaminate the solder or steel to the point that you cannot successfully flux, tin or solder.

2) The first step is to Tin the outside of the liner with solder. Thoroughly degrease and lightly sand the outside of the liner. Clamp the muzzle end of the liner between 2 blocks of wood in a vertical position in your bench vise, chamber end up. Try to

have all the length of liner needed exposed for ease in tinning. (With an approximately 30" long liner and no more than 28" usually needed, you will have about 2" to clamp into the vise.) If you cannot tin the entire length without moving the liner in the vise; **Do Not** swap ends. Keep the chamber end up, but just slide the liner down through the blocks and vise, and continue tinning the liner sticking below the vise. If you flip ends, you'll have a ridge of solder where the 2 solder sections meet that can make inserting the liner difficult.

Apply a liberal amount of flux to the liner's surface. The flux will clean the surface and also float away any impurities during the application of the solder. (Caution: The flux is a very aggressive cleaner; it can cause surface rust/corrosion quickly on uncoated/unprotected metal, including the surfaces of your vise. Use with care.)

**3)** Apply heat to the liner until it will melt the solder applied to it. (The liner metal must melt the solder, not the heat source.) The molten solder will run and cover a large area of the liner. While the solder is still in the molten state, wipe the liner surface with a clean, soft cloth. This removes the excess solder and leaves the liner coated or tinned with a thin film of clean solder. Do not handle this tinned surface with your greasy hands; it will contaminate the surface and can keep the solder from bonding properly.

**4)** Next, the drilled hole in the barrel must be tinned. Mount it the same way you did the liner; in the bench vise, chamber end up. Dip a wire-bristled bore brush (mounted on a cleaning rod) into the flux and run it through the barrel several times. Apply heat to the outside of the barrel until the solder placed on the INNER drilled surface will melt and run into the hole. (You will need 2 propane torches to supply enough heat.) The entire barrel must be heated sufficiently, from muzzle to chamber, to keep the molten solder running the full length of the drilled hole. Use the fluxed bore brush to spread the solder until the hole is completely tinned over its full length.

**5)** Thoroughly flux the newly tinned liner over its entire surface. Plug the chambered end of the liner with modeling clay and start that end into the drilled hole in the barrel at the muzzle end. While applying heat to the full length of the barrel with 2 propane torches, begin gently tapping the liner up into the hole. The barrel must be kept hot enough over its entire length to keep the solder molten for the liner to slide into the hole. Correctly done, the solder on the liner and the solder in the drilled hole will melt and fuse together, securely bonding the liner and barrel together when they cool.

**6)** The heat necessary to properly solder the barrel liner in place will cause very rapid oxidation (rusting!). You must apply a good coat of light machine oil to both the inside of the liner and the outside of the barrel as soon as they cool from the soldering. (Brownells "Pro-Tek" is an excellent non-additive mineral oil to use.)

#### FINAL FITTING & CLEANUP - ALL METHODS -

**1)** Cut the liner off at the muzzle with a hacksaw, leaving approximately 1/8" of excess liner showing. File the liner down until it is flush with the muzzle (See Figure 13A & 13B).

**2)** If the barrel had a unique concave crown that you wish to match, this is best cut on a lathe, but the job can be done by hand with a tool you can make in your shop. Chuck an appropriately sized piece of drill rod into your electric hand drill (or drill press), and with the drill running, file the rod until it matches the shape of the original crown. Coat the end of the shaped rod with fine grinding compound and, keeping a layer of compound between the head and the liner, lightly grind away the edge of the liner until it blends in with the original crown.



**FIGURE 13A** - Hacksaw excess liner off.

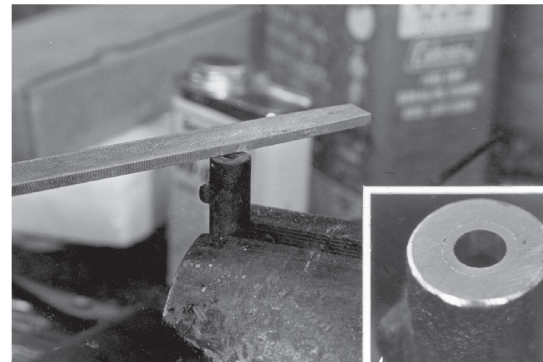

**FIGURE 13B** - File flush and square with muzzle (see insert).

On barrels where the muzzle is flat, file the liner until it matches the original barrel. Finish up by using a large, round-head brass bolt or screw chucked in your electric hand drill with fine grinding compound between the bolt head and the liner (See Figure 14). All that is necessary is to lightly grind away the edge of the liner using the rotation of the bolt to assure uniform metal removal.

An easier, more precise method of facing off and chamfering the barrel muzzle is to use Brownells Rifle Muzzle Facing & Chamfering Tools. They use interchangeable cutters and pilots and are hand turned, eliminating the need for a lathe.

When shaping a crown, it's a good idea to plug the bore with a cleaning patch, about one-half inch down from the end, or 1/2" deeper than the pilot, to prevent the chips and filings from dropping into and collecting in the bore of the new liner. When work is done, patch can be pushed out from other end with a cleaning rod.



**FIGURE 14** - Crowning the new liner using a round-headed brass bolt coated with fine grinding compound and mounted in an electric drill. Lightly bevel the inside edge of the new liner to blend with the original crown.

**3)** With care, the liner will blend in with original barrel and be almost invisible. Dicropan T4™ Touch-Up Blue can

be applied to both the muzzle and chamber end of the liner to help in matching finishes if the barrel is not to be reblued. As previously stated, **ACRAGLAS**-bonded liners can be run through a regular immersion, hot blue without the liner coming loose.

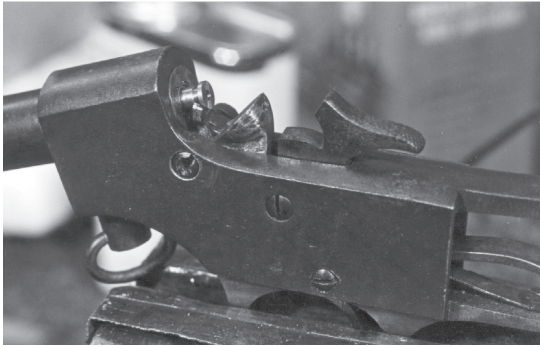

**FIGURE 15** - "Go" gauge in place for final check fit before test-firing. Breech block should close easily but snugly on the "Go" gauge.

4) The final step is to clean everything up, finish reassembling the rifle, check headspace once more with the "Go" gauge (See Figure 15) and test-fire to assure correct functioning.

### RELINING PISTOL AND REVOLVER BARRELS AND CYLINDERS

Relining pistol/handgun barrels follows essentially the same procedure as used for relining rifles. However, you must carefully look over the gun you are proposing to reline to be sure that; **1)** it is worth the work, **2)** the condition of the barrel and cylinder are otherwise safe to be used for shooting, and **3)** you understand the loading and firing function fully so when relining the barrel, you get all the necessary feed ramps, extractors-ejectors, etc., accounted for in the relining. Above all, be sure you know and understand what the relining is going to remove, what it will leave, and how safe the relining job is going to leave the handgun.

### SEMI-AUTO PISTOLS

Semi-Auto pistol barrels follow the same lining procedures as those used on relining rifle barrels. Most semi-auto pistol barrels use a feed or bullet-guide ramp, and the cartridge head is usually recessed in the face of the breech bolt.

### REVOLVER BARRELS

Relining revolver barrels also uses the procedure used in relining rifle barrels. You must watch to be sure the end of the liner is flush with the breech end of the original barrel so the cylinder will turn without binding. Also, the liner should be lightly chamfered as was the original barrel, to guide the bullet leaving the cylinder, neatly into the bore.

### REVOLVER CYLINDERS

.22 Caliber Revolver Cylinders can be relined also, using the same procedures as in relining barrels. You must check to be sure enough wall material will be left in the cylinder after drilling it out to accept the new liners. All rifling must be removed from the cylinder liners in front of the chamber area once the liners are in place. This is best done with a .22 throating reamer.

### WILLIS SPRUNGER on...

#### DRILLING THE BARREL ON A LATHE

We asked Willis Sprunger of Pitzer Gun Shop, Winterset, Iowa, to write about how he made a long extension drill for drilling out .22 barrels, and how to do the drilling on a lathe. Willis did a real nice job of covering that, and also sent along comments on **ACRAGLAS**ing in the liner, time requirements, some tuning up tips once the liners are in, and other interesting and very useful suggestions.

We've tried to include everything that's new or different, or not already covered by the other 2 instruction sections.

#### MAKING A DRILL

The drill I used on this job is just an ordinary Chicago Latrobe  $\frac{5}{16}$ " bit, with a pilot ground on, the shank drilled  $\frac{1}{4}$ ", and a 24" piece of cold-rolled silver soldered into the hole in the shank. I have tried pull reamers with oil feed and push drills with three cutting edges and oil feed, (which push out the chips with oil) and the gun barrel drills with "V" grooves and oil feed. I have also tried using a drill without a pilot ground on the end...Disaster Guaranteed using that drill, so DON'T!!

#### DRILLING THE BARREL ON A LATHE

**1)** Remove barrel from rifle and mount on your lathe, centering to the bore, not the outside of the barrel. (We will not go into further details here - too many variables from size of lathe to amount of taper on barrel to be discussed. The presumption is that you know how to operate your equipment to be able to do deep drilling.)

**2)** Using the appropriate boring bar, bore the chamber end of the barrel to the diameter of your liner (O.D. .311 to .3125") to a depth of  $\frac{1}{4}$ " to  $\frac{1}{2}$ ". This will give the cutting part of the drill a start so it won't catch on an extractor slot when you start drilling.

**3)** Place the tool post so it is exactly on center line with the barrel's bore. Clamp the drill shank about 6" behind the point in the tool post (you'll have to design your own clamp, and long flute drills may require a different one). Check to be sure everything is lined up properly and set spindle and carriage to desired speed (recommend 600 RPM) and feed (recommend about .002" per revolution).

**4)** With a pump oil can, give 1 or 2 squirts of Do-Drill cutting oil down the bore and on the drill, and engage the feed. Place a small block of steel about  $\frac{3}{8}$ " ahead of the carriage and when the carriage reaches the block, back the drill out, brush off the chips and give bore and drill another squirt or two of Do-Drill.

**5)** Move the carriage back up to the block of steel, reset the block another  $\frac{3}{8}$ " ahead and drill out another  $\frac{3}{8}$ " of the bore. (Using a drill with longer flutes you may be able to go further without cleaning out the chips.)

**6)** When the tool post clamp is about an inch from the end of the barrel, slide it back on the drill 6" or 7" and continue the drilling process. You can continue until you are completely through the barrel, or you can drill in only halfway, switch the barrel end-for-end and drill the other half. (That way you won't have to drill quite so deeply.)

**7)** Take the barrel out of the lathe and degrease it thoroughly, both the drilled-out bore and the outside.

**8)** Cut about 1" off the end of the liner to be sure to get rid of any possible damaged rifling and polish a slight taper on the end. Measure the barrel to determine the length of liner needed and add 2" to that figure. Beginning at the newly cut and polished end, measure the amount of liner required, and cut off. Finally, plug the polished/tapered end with a wooden plug, tapered to fit snugly, but not too tightly.



9) You are now ready to bond with **ACRAGLAS** or solder.

### COMMENTS

1) When **ACRAGLAS**ing the liner in, coat both liner and inside of drilled hole in the barrel thoroughly with **ACRAGLAS**. Starting from the receiver end of the barrel, slide the plugged end of the liner in first and push it through the bore. Keep a ring of **ACRAGLAS** at the breech as the liner goes in to be sure there are no voids at the chamber end.

2) Actual drilling time is a little over an hour. Chambering, crowning, cutting extractor slots and installing liner takes about another hour. Charges are usually for time plus cost of the liner.

3) When test-firing - especially on an older gun - be sure to check the condition of the firing pin. Poor ignition may well be cured by chisel-pointing the old firing pin, or even replacing it.

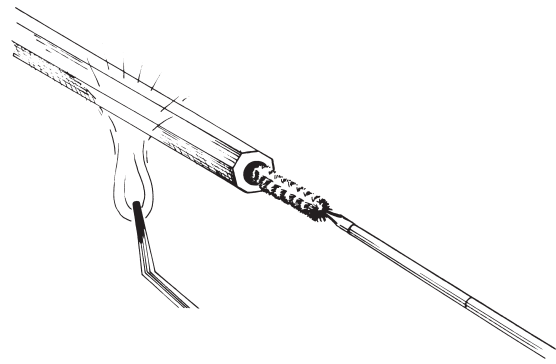

**FIGURE 16** - Barrel must be kept hot while applying solder to prevent brush from sticking.

**BOB SCHUETZ on...**

### HI-FORCE 44 SOLDERING THE BARREL LINER IN

We asked Bob Schuetz, SGW, Inc., Olympia, Washington, to put us together some instructions on how to correctly solder barrel liners in place for those in the fraternity who still prefer to bond liners in place with soft solder. Bob succeeded admirably in the task, and his instructions follow.

#### TINNING THE LINER AND BARREL

1) After drilling out the rifle bore, check to be sure the liner will fit. Clean the outside of the liner with 180 grit emery paper. When the surface is smooth, the liner should slide into the drilled bore of the barrel with a minimum amount of force.

2) Thoroughly clean and degrease the barrel and liner with TCE Cleaner/Degreaser (or equivalent) to remove all cutting oil, grease and other crud. See comments on cleaners in first part of instructions.

3) Hold the liner securely by one end with a set of wood blocks in your bench vise, and tin the surface of the liner. Wear a pair of heavy gloves, like a pair of welder's gloves. Saturate a very small piece of #00 Steel Wool in the No. 4 Comet Flux and rub the outside of the liner thoroughly. Work from the vise on out to the end of the liner.

4) Heat the liner with a torch until the Brownells Hi-Force 44 solder melts and flows when touched to the liner not directly under flame. Apply the solder directly to the liner, and using the steel wool you applied the flux with, wipe the solder down the full length of the liner. Be sure to maintain the temperature to get a good, even coverage.

5) Next, tin the inside of the barrel. Using either a brass or aluminum rod fitted with a .32 caliber brass bore brush, wrap a small wad of #00 steel wool around the bore brush. It clings well, and makes the bore brush a solid mass. Dip the brush into the No. 4 Comet Flux and apply liberally to the inside of the barrel. When the entire barrel is heated to the working temperature of the solder, apply solder to the breech end of the bore, and keeping the barrel hot through its entire length, spread solder inside the bore with the steel wool swab you make for applying flux. Continue melting solder into the bore and swabbing it around until you have a good, even coating on the entire inside surface. If the swab and rod hang up on you in there, you don't have the barrel hot enough, and you must apply more heat.

It would be to your advantage to make a fixture that would hold the barrel while tinning and relining. The rod or swab will hang up frequently in the barrel if the barrel is not brought up to the proper working temperature. (See Figure 16.)

#### JOINING BARREL & LINER

1) Be sure both liner and barrel are brought back to the working temperature of the solder and held there. Liberally flux both outside liner and inside of barrel again. Touch a little more solder to each piece and heat until flows the same on both pieces.

2) Start the liner into the breech end of the barrel with the muzzle pointed downward. Melt a little solder where the liner is entering the barrel at the chamber end. This will feed down through the full length of the barrel and liner because both pieces are up to temperature and both surfaces are tinned.

3) Once the liner has slid into position in the barrel, secure the heat, but be sure to stay right with the barrel and liner to see that the liner does not slip either up or down, or around inside the bore until the solder has cooled.

4) After the barrel and liner have cooled down, you can trim the ends of the liner in preparation for chambering.

#### SPECIAL NOTES AND OTHER CONSIDERATIONS

**(Ed. Note:** This section of the Instructions is to cover, in an informal manner, all the aside information, comments, bits and pieces, and so on that come to light while drilling, bonding and finishing barrel lining jobs. New "Kinks<sup>®</sup>" and info will be added as they come up, and we welcome hearing your suggestions and comments for inclusion in this section of future instruction booklets.)

1) In lining .22 Rimfire barrels, we discovered, as I'm sure many of you have, that many .22 barrels are not straight. For your own amazement, check out a few to see just how crooked many of them are. Therefore, it is the accuracy of the barrel that is important, not its straightness.

2) Drilling the hole in the barrel for the barrel liner with a piloted drill can be as easy or as hard as you want to make it. We found that a 3/8", variable speed, electric hand drill will work if you are extremely patient. However, most 3/8" drills we have had experience with do not have enough torque to do the job with any kind of speed or ease. After trying a number of electric drills, we found a fixed speed (560 RPM), heavy duty, 1/2" drill with a 5 amp draw that worked beautifully for us. It simply sat there and ate its way through the barrel at an extremely rapid rate, making it a very easy operation. A lighter weight drill constantly jammed the bit into the hole and did not have the torque necessary to break all the chips free and continue cutting. We also found the Skil 1/2" Extra Tool with the hammer drill feature to be very helpful in breaking tough chips free. Whatever drill is used, you must use a great deal of Do-Drill cutting oil to prevent damage to the drill, and you must clean out the chips frequently. We found an M16 brush did the job ideally.

3) If the bore of the original barrel being drilled out is slightly undersized and the pilot on the piloted drill you bought from Brownells does not enter, do not attempt to drill. A properly sized pilot must be either obtained or ground. This undersize bore has shown up on a few older guns. You'll have to be aware they exist and watch for them.

4) When mounting the barrel in the vise prior to **ACRAGLAS**ing the liner in, there are many options and ways you can go; each with its own advantages and disadvantages. Please do follow the discussion closely and, hopefully we can save you some grief and mess.

Realistically, the barrel can be mounted in the vise breech up or down, vertically or horizontally and at all the angles in between. After trying many different angles, we finally decided that we preferred an essentially vertical position with a 20° to 30° angle to one side. As for whether to insert the liner from the breech end or the muzzle end: We found no real advantage one way or the other, except that it seemed to be easier and much cleaner if we mounted the barrel in the vise with the breech end up and inserted the liner from the muzzle, sliding up toward the breech. (Leave enough room between the end of the barrel and the floor to get the liner started.) This method of insertion pushed a small ring of **ACRAGLAS** ahead of the barrel liner. The excess **ACRAGLAS** on the outside of the liner was scraped off as the liner entered the muzzle end of the barrel and ran down into a cardboard box on the floor. However, you can insert from either end, using just about any technique you like. The whole secret is to get the excess **ACRAGLAS** out of your way with a minimum amount of mess on you, the bench, the gun, the floor and so on.



Short, Piloted Barrel Liner Drill - Center drill and drill 1"-1 1/4" deep - See instructions for suggested hole diameter.

Drill Extension - Lightly chamfer/break sharp edges. Length of turned section to match drilled hole in shank of drill. Diameter of turned section .002" smaller than drilled hole.

Degrease both the drilled hole in the Liner Drill and the turned end of the extension using TCE Cleaner/Degreaser. Clamp the extension vertically in the bench vise, with about 4" to 6" of the turned end extending above the vise jaws, turned end uppermost. Lightly flux both the extension's turned end and the drilled hole in the shank of the Liner Drill with silver solder flux and place a 1/2" long piece of 1/16" diameter silver solder in the heat Liner Drill hole. Protect flutes of the drill from excess heat with Brownells Heat Stop Heat Control Paste. Heat the Liner Drill and extension together, using an oxyacetylene torch. **CAUTION:** Provide the adequate ventilation; use welding goggles to protect the eyes, and clear the area around the vise of any flammable materials. If the Liner Drill does not seat on the extension by its own weight, use a pair of needle nose pliers to push the Liner Drill onto the extension as the silver solder melts. **DO NOT** use your best pliers; any excessive heat transferred to the pliers may ruin them for small parts holding or metal bending.

Allow the parts to cool completely in the vise before removing them. Clean up any excess flux from the parts following the manufacturer's directions. Be certain that no excess flux or silver solder remains on the shank of the Liner Drill itself; this can cause the Liner Drill to bind in the drilled hole, and possibly ruin the barrel, break the drill, or both.

**GUIDE THE DRILL PILOT INTO THE BORE:** When drilling a .32-20 barrel, keep in mind that these barrels were usually made of tougher/harder steel than most .22 RF barrels. Be Patient!

If you find the Liner Drill pilot is larger than the bore of the barrel, the pilot will have to be ground to fit. The pilots of our Short, Piloted Barrel Liner Drills have been ground to just under SAAMI specifications for their respective calibers. Some older guns, built long before the standardization barrel and cartridge dimensions, may have undersized bores.

When drilling from the breech end of the barrel - the recommended method - machine a bushing to support the pilot while it is in the chamber, before it reaches the bore. A less effective but simpler pilot bushing can be made from the front half of an empty .32-20 cartridge case. After the chamber has been drilled out to about half its depth, the pilot bushing can be removed. At this point, the Liner Drill's pilot will be supported by the bore.

Place the pilot bushing on the drill's pilot, oil the chamber and pilot end of the Liner Drill, and place the Liner Drill pilot into the chamber. Make sure the Liner Drill is aligned properly with the bore. You can check easily for side-to-side alignment. Have a second person check the vertical alignment the first few times you drill a barrel. You will soon get the hang of it. Back the cutting edge of the Drill Liner away from the barrel by about 1/32" and turn it on. Use a SLOW SPEED - about 80 to 300 rpm -- and advance the Liner Drill into the chamber. If the Liner Drill tries to catch in the starting cut, stop immediately and remove it. Use a small scraper, Dremel hand grinder with small stones, or files, as appropriate, to remove any burrs kicked up by the Liner Drill, and start over. Do not switch the drill motor into reverse and try to spin it out of the cut...you may break it. If it jams in the hole, turn the drill backward BY HAND until the cutting edge is clear,

### SPECIAL INFORMATION FOR LINING .32-20 BARRELS

The basic process is the same for lining .32-20 barrels as for .22's, there are just a few things you need to do a little differently. The first difference is the drill required to open up your old barrel for a Brownell/Redman .32-20 liner. A 13mm drill is needed but the cost on a full-length drill is prohibitive. To solve the problem, we've had a pilot precision-ground on a standard length drill and will show you how to add your own extension. Second, we'd recommend you use a 1/2" electric drill motor with at least 1/2 hp, to drive the large bit. Third, you'll need to work up a pilot system to get the drill's pilot through the chamber and into the bore. Read the info that follows on extending the drill and making a pilot bushing, then follow the .22 basic procedures.

### ALTERING THE DRILL & ATTACHING THE EXTENSION:

Degrease the Liner Drill and chuck it in the lathe so only about 5/8" of the butt end of the shank protrudes from the chuck. Use a dial indicator to make sure the drill is true in the jaws of the chuck, and adjust if needed. Mount a Jacobs chuck in the tailstock and install a center-drill. Center-drill the drill's shank using plenty of Do-Drill or other good cutting oils. Use a sharp drill with plenty of Do-Drill; clear your chips frequently, and use an appropriate speed for the drilling operation. Use a drill one size smaller than the Extension Rod you are going to attach. The hole should be 1" to 1 1/4" deep. (For a 5/16" diameter extension, drill shank with a Letter Drill #N, .302" drill.) Remove the Barrel Liner Drill from the lathe, chuck the extension rod in the lathe leaving about 1 1/2" protruding from the jaws of the chuck. Turn the end of the extension to about .002" smaller than the hole drilled in the Liner Drill, and to the same depth as the drilled hole. See illustration for more details.

and then remove the Liner Drill from the cut while the motor is turning with forward rotation.

The limiting factor in how much metal can be removed at each cut is the hardness/toughness of the barrel material, speed of the drill motor, degree of sharpness of the drill and flute length of the drill. If the flutes become fully packed with chips, the Liner Drill may jam in the hole and break. Depending on the above factors, clear the Liner Drill of the chips every  $\frac{1}{4}$ " to  $\frac{7}{16}$ " of travel, minimum. Use plenty of Do-

Drill or other good grade cutting oil to help lubricate the cut and help keep the Liner Drill from overheating. It's cheap insurance against a jammed or broken drill...GIVE THE LINER DRILL AND HOLE A GOOD SQUIRT EVERY TIME IT GOES INTO THE BARREL.

**NOTE:** Brownells/Redman Barrel Liners have a groove cut on the outside of the liner at one end. THIS IS THE BREECH END of the liner. Position the groove so it will be removed completely when the breech end of the liner is faced off.

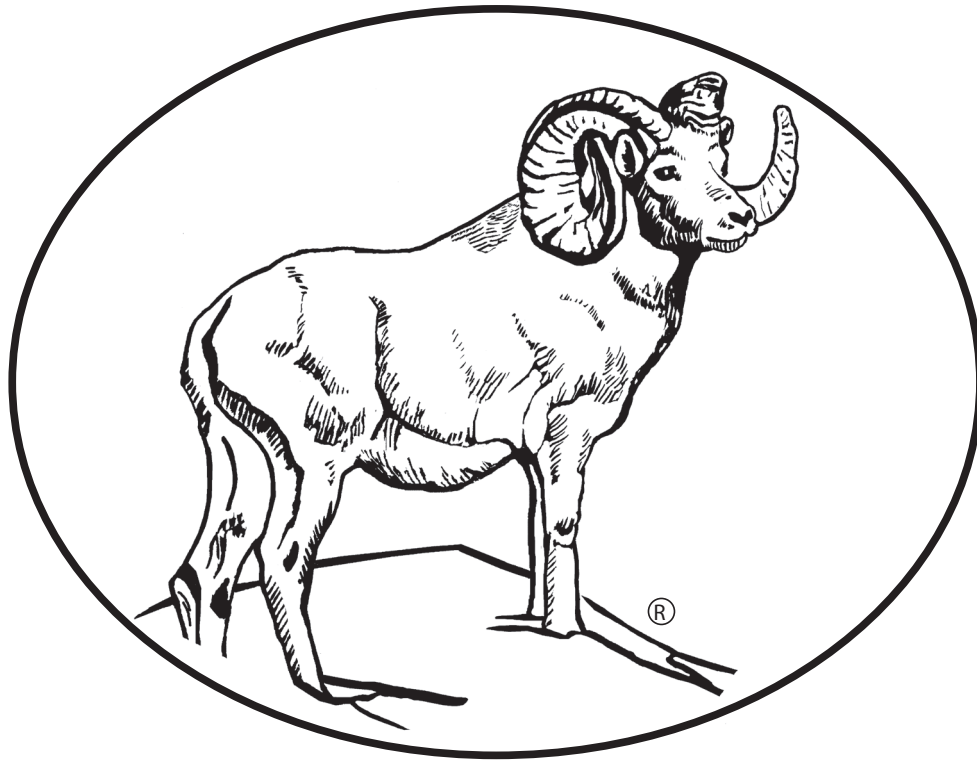

# **BROWNELLS**

*SELECTION. SERVICE. SATISFACTION.*®

**200 S. Front St. Montezuma, IA 50171**  
**800-741-0015 or 641-623-4000 • [www.brownells.com](http://www.brownells.com)**

**World's Largest Supplier of Firearms Accessories and Gunsmithing Tools.™**